

Introduction to Artificial Intelligence

Tushar B. Kute,
<http://tusharkute.com>

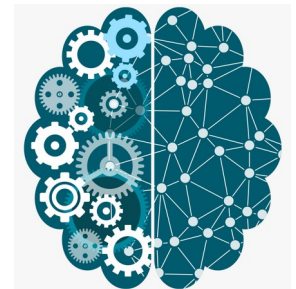



WHAT IS A.I.?

Artificial Intelligence

- The intelligence demonstrated by machines is known as Artificial Intelligence.
- Artificial Intelligence has grown to be very popular in today's world. It is the simulation of natural intelligence in machines that are programmed to learn and mimic the actions of humans.
- These machines are able to learn with experience and perform human-like tasks.
- As technologies such as AI continue to grow, they will have a great impact on our quality of life.

Artificial Intelligence

- Artificial Intelligence is composed of two words Artificial and Intelligence, where Artificial defines "man-made," and intelligence defines "thinking power", hence AI means "a man-made thinking power."
- So, we can define AI as:
 - "It is a branch of computer science by which we can create intelligent machines which can behave like a human, think like humans, and able to make decisions."

Artificial Intelligence

- The short answer to What is Artificial Intelligence is that it depends on who you ask.
- A layman with a fleeting understanding of technology would link it to robots.
- They'd say Artificial Intelligence is a terminator like-figure that can act and think on its own.
- If you ask about artificial intelligence to an AI researcher, (s)he would say that it's a set of algorithms that can produce results without having to be explicitly instructed to do so. And they would all be right.

Artificial Intelligence

- So to summarise, Artificial Intelligence meaning is:
- Artificial Intelligence Definition
 - An intelligent entity created by humans.
 - Capable of performing tasks intelligently without being explicitly instructed.
 - Capable of thinking and acting rationally and humanely.

Artificial Intelligence

- Artificial Intelligence exists when a machine can have human based skills such as learning, reasoning, and solving problems
- With Artificial Intelligence you do not need to preprogram a machine to do some work, despite that you can create a machine with programmed algorithms which can work with own intelligence, and that is the awesomeness of AI.
- It is believed that AI is not a new technology, and some people says that as per Greek myth, there were Mechanical men in early days which can work and behave like humans.

Artificial Intelligence : Design Goals

- **Teach machines to reason** in accordance to perform sophisticated mental tasks like playing chess, proving mathematical theorems, and others.
- **Knowledge representation for machines** to interact with the real world as humans do — machines needed to be able to identify objects, people, and languages. Programming language Lisp was developed for this very purpose.
- **Teach machines to plan and navigate around the world** we live in. With this, machines could autonomously move around by navigating themselves.

Artificial Intelligence : Design Goals

- Enable machines to **process natural language** so that they can understand language, conversations and the context of speech.
- Train machines to perceive the way humans do **touch, feel, sight, hearing, and taste**.
- General Intelligence that included **emotional intelligence, intuition, and creativity**.

Artificial Intelligence : Evolution

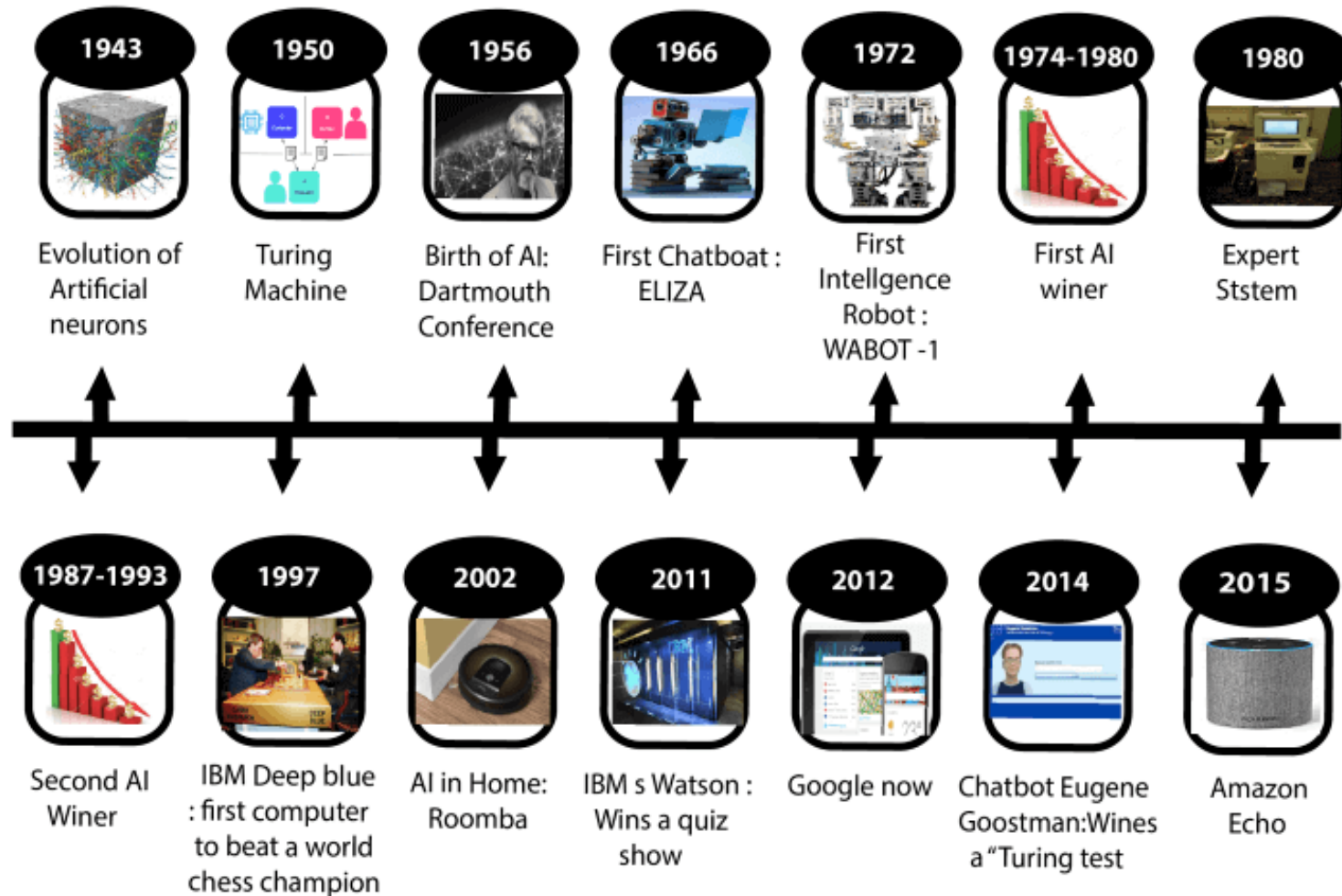

Biological Neuron

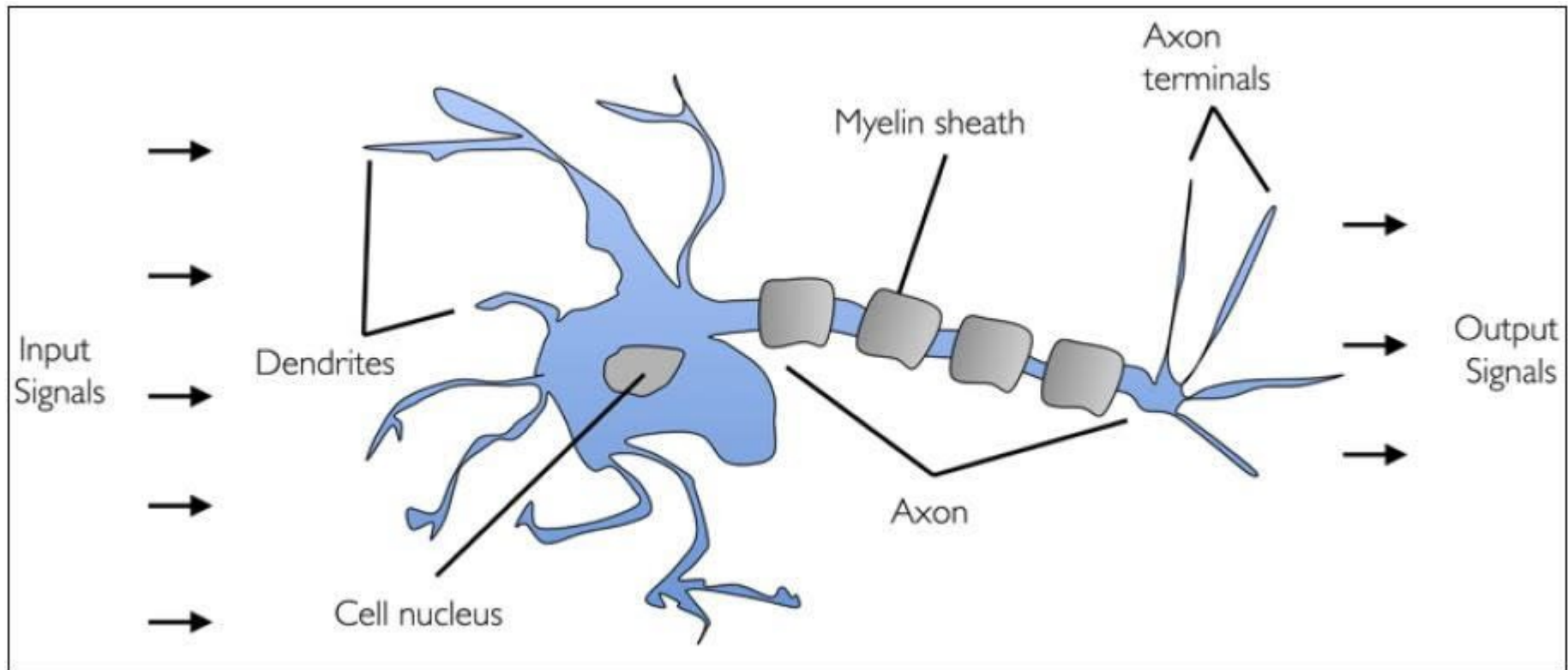

Artificial Neuron

- Researchers Warren McCullock and Walter Pitts published their first concept of simplified brain cell in 1943.
- This was called McCullock-Pitts (MCP) neuron. They described such a nerve cell as a simple logic gate with binary outputs.
- Multiple signals arrive at the dendrites and are then integrated into the cell body, and, if the accumulated signal exceeds a certain threshold, an output signal is generated that will be passed on by the axon.

Artificial Neuron

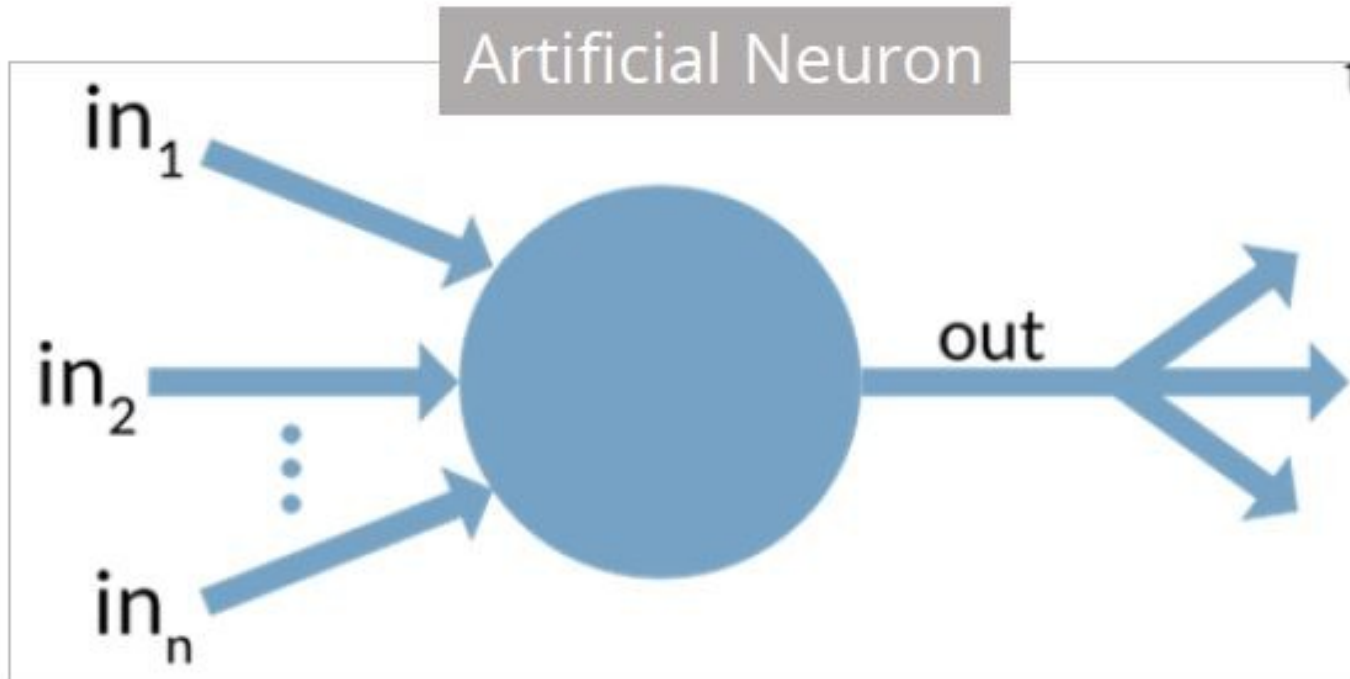

Biological vs. Artificial Neuron

Biological Neuron	Artificial Neuron
Cell Nucleus (Soma)	Node
Dendrites	Input
Synapse	Weights or interconnections
Axon	Output

Artificial Neuron

- The artificial neuron has the following characteristics:
 - A neuron is a mathematical function modeled on the working of biological neurons
 - It is an elementary unit in an artificial neural network
 - One or more inputs are separately weighted
 - Inputs are summed and passed through a nonlinear function to produce output
 - Every neuron holds an internal state called activation signal
 - Each connection link carries information about the input signal
 - Every neuron is connected to another neuron via connection link

Perceptron

- A perceptron is a neural network unit (an artificial neuron) that does certain computations to detect features or business intelligence in the input data.

Perceptron (1957)

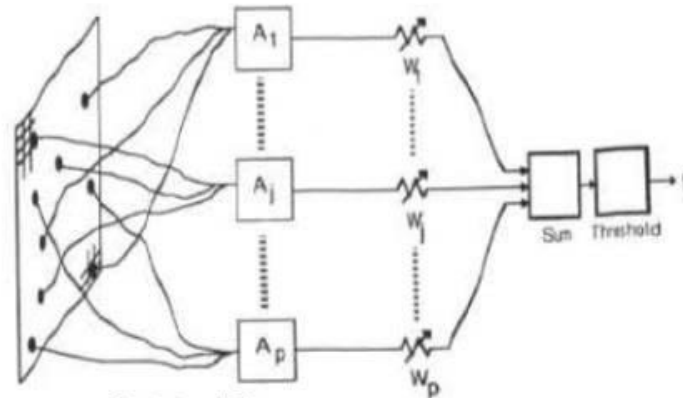

Frank Rosenblatt
(1928-1971)

Original Perceptron

(From Perceptrons by M. L. Minsky and S. Papert, 1969, Cambridge, MA: MIT Press. Copyright 1969 by MIT Press.)

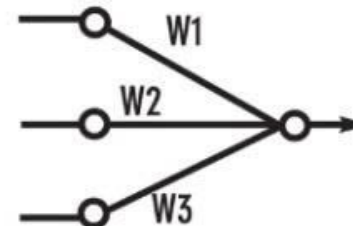

Simplified model:

Perceptron

- Perceptron was introduced by Frank Rosenblatt in 1957.
- He proposed a Perceptron learning rule based on the original MCP neuron.
- A Perceptron is an algorithm for supervised learning of binary classifiers.
- This algorithm enables neurons to learn and processes elements in the training set one at a time.

Turing Machine

- A Turing machine is a mathematical model of computation that defines an abstract machine that manipulates symbols on a strip of tape according to a table of rules.
- Despite the model's simplicity, given any computer algorithm, a Turing machine capable of simulating that algorithm's logic can be constructed.

Turing Machine

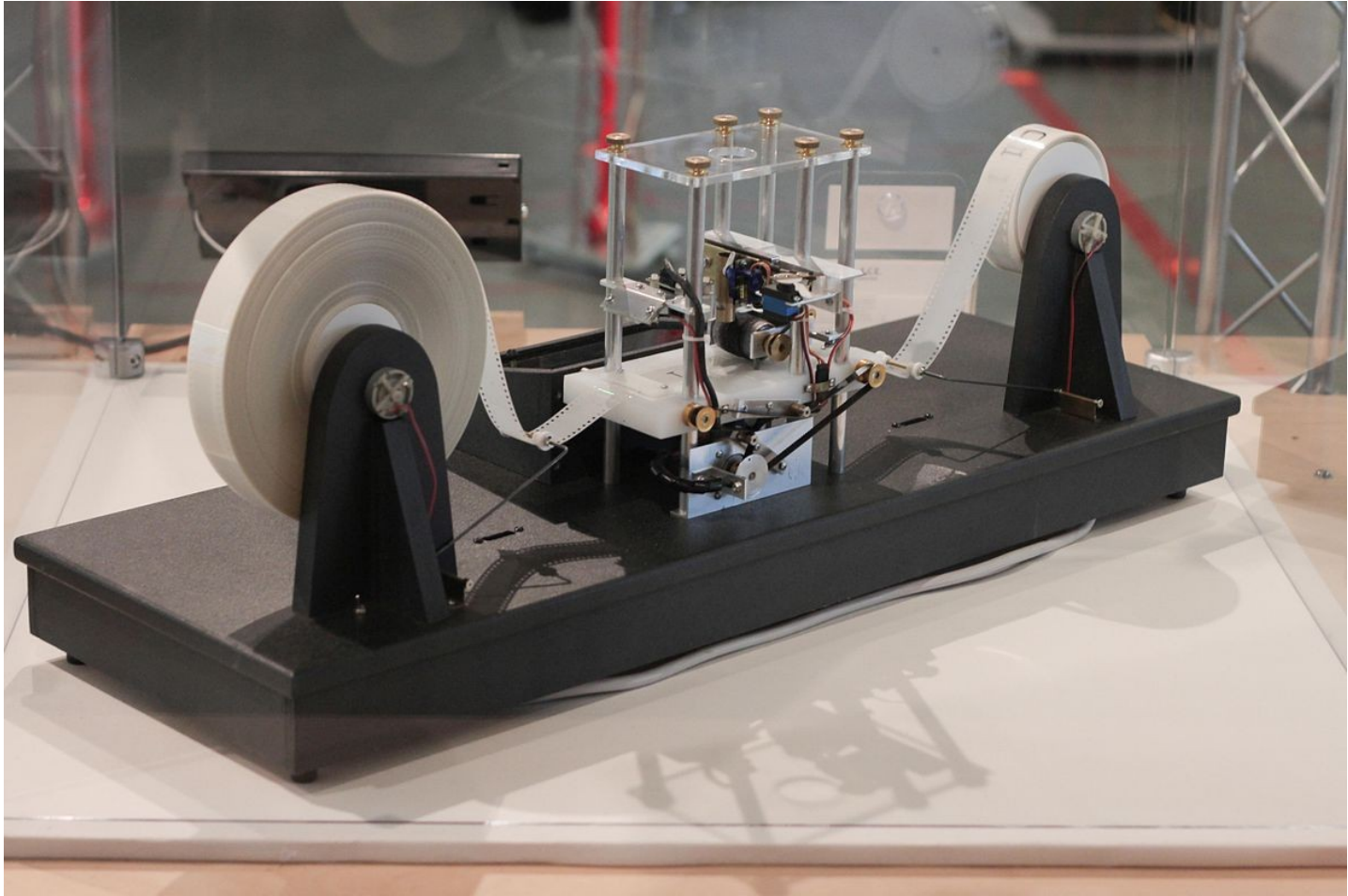

Turing Machine

- The Turing machine was invented in 1936 by Alan Turing, who called it an "a-machine" (automatic machine). With this model, Turing was able to answer two questions in the negative:
 - Does a machine exist that can determine whether any arbitrary machine on its tape is "circular" (e.g., freezes, or fails to continue its computational task)?
 - Does a machine exist that can determine whether any arbitrary machine on its tape ever prints a given symbol?

Dartmouth workshop

- The Dartmouth Summer Research Project on Artificial Intelligence was a 1956 summer workshop widely considered to be the founding event of artificial intelligence as a field.
- The project lasted approximately six to eight weeks and was essentially an extended brainstorming session.
- Eleven mathematicians and scientists originally planned to attend; not all of them attended, but more than ten others came for short times.

Dartmouth workshop

- In 1955, John McCarthy, then a young Assistant Professor of Mathematics at Dartmouth College, decided to organize a group to clarify and develop ideas about thinking machines. He picked the name 'Artificial Intelligence' for the new field.
- He chose the name partly for its neutrality; avoiding a focus on narrow automata theory, and avoiding cybernetics which was heavily focused on analog feedback, as well as him potentially having to accept the assertive Norbert Wiener as guru or having to argue with him.
- On September 2, 1955, the project was formally proposed by McCarthy, Marvin Minsky, Nathaniel Rochester and Claude Shannon. The proposal is credited with introducing the term 'artificial intelligence'.

GAME AI

- In 1951, using the Ferranti Mark 1 machine of the University of Manchester, Christopher Strachey wrote a checkers program and Dietrich Prinz wrote one for chess.
- Arthur Samuel's checkers program, developed in the middle 50s and early 60s, eventually achieved sufficient skill to challenge a respectable amateur.
- Game AI would continue to be used as a measure of progress in AI throughout its history.

Arthur Samuel

- Arthur Lee Samuel was an American pioneer in the field of computer gaming and artificial intelligence.
- He popularized the term "machine learning" in 1959.
- The Samuel Checkers-playing Program was among the world's first successful self-learning programs, and as such a very early demonstration of the fundamental concept of artificial intelligence (AI)

Eliza

- ELIZA is an early natural language processing computer program created from 1964 to 1966 at the MIT Artificial Intelligence Laboratory by Joseph Weizenbaum.
- Created to demonstrate the superficiality of communication between humans and machines, Eliza simulated conversation by using a "pattern matching" and substitution methodology that gave users an illusion of understanding on the part of the program, but had no built in framework for contextualizing events

Eliza

Welcome to

```
EEEEEE LL      IIII  ZZZZZZ  AAAAA
EE      LL      II     ZZ     AA   AA
EEEEEE LL      II     ZZZ    AAAAAA
EE      LL      II     ZZ     AA   AA
EEEEEE LLLLLL IIII  ZZZZZZ  AA   AA
```

Eliza is a mock Rogerian psychotherapist.
The original program was described by Joseph Weizenbaum in 1966.
This implementation by Norbert Landsteiner 2005.

```
ELIZA: Is something troubling you ?
YOU:   Men are all alike.
ELIZA: What is the connection, do you suppose ?
YOU:   They're always bugging us about something or other.
ELIZA: Can you think of a specific example ?
YOU:   Well, my boyfriend made me come here.
ELIZA: Is it important to you that your boyfriend made you come here ?
YOU:   He says I'm depressed much of the time.
ELIZA: I am sorry to hear that you are depressed.
YOU:   It's true. I am unhappy.
ELIZA: Can you explain what made you unhappy ?
YOU:
```

Eliza

- The most famous script, DOCTOR, simulated a Rogerian psychotherapist (in particular, Carl Rogers, who was well-known for simply parroting back at patients what they had just said), and used rules, dictated in the script, to respond with non-directional questions to user inputs.
- As such, ELIZA was one of the first chatterbots and one of the first programs capable of attempting the Turing test.

WABOT-1

- The WABOT-1 was the first fun-scale anthropomorphic robot developed in the world. It consisted of a limb-control system, a vision system and a conversation system.
- The WABOT-1 was able to communicate-with a person in Japanese and to measure distances and directions to the objects using external receptors, artificial ears and eyes, and an artificial mouth.
- The WABOT-1 walked with his lower limbs and was able to grip and transport objects with hands that used tactile-sensors.
- It was estimated that the WABOT-1 has the mental faculty of a one-and-half-year-old child. WABOT-1 consisted of the WAM-4 (as its artificial hands) and the WL-5 (Its artificial legs).

WABOT-2

- In 1980, our laboratories joined in a joint project again and commenced the WABOT-2 project.
- Playing a keyboard instrument was set up as an intelligent task that the WABOT-2 aimed to accomplish, since an artistic activity such as playing a keyboard instrument would require human-like intelligence and dexterity. Therefore the WABOT-2 was defined as a "specialist robot" rather than a versatile robot like the WABOT-1.
- The robot musician WABOT-2 can converse with a person, read a normal musical score with is eye and play tunes of average difficulty on an electronic organ.
- The WABOT-2 is also able of accompanying a person while he listens to the person singing. The WABOT-2 was the first milestone in developing a "personal robot".

WABOT-1

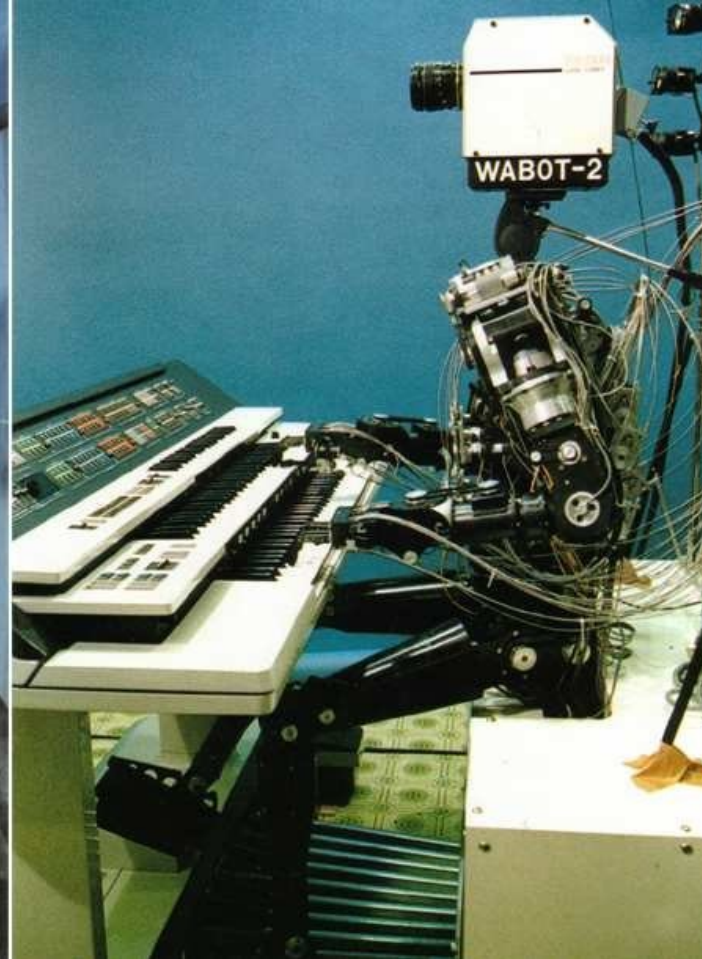
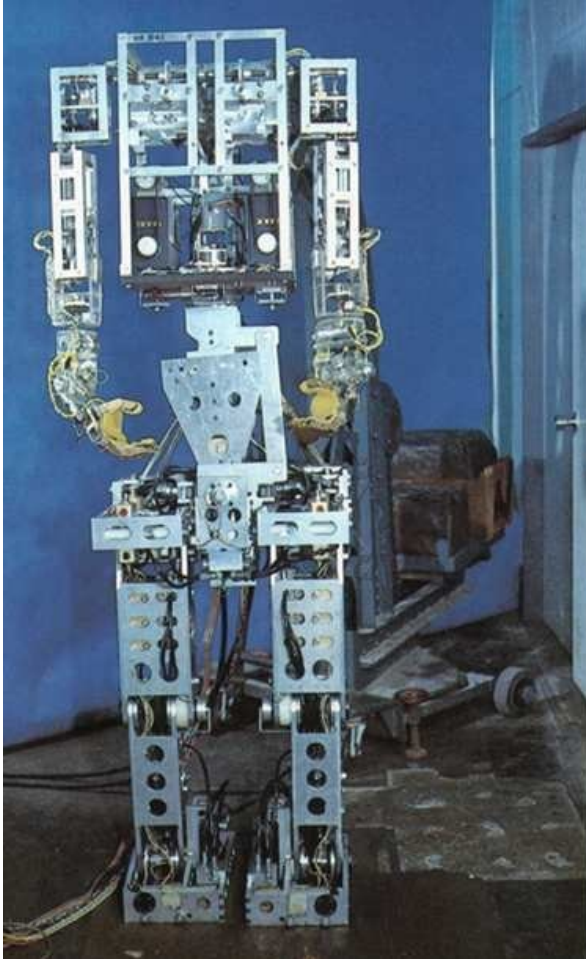

Expert Systems

- In artificial intelligence, an expert system is a computer system emulating the decision-making ability of a human expert.
- Expert systems are designed to solve complex problems by reasoning through bodies of knowledge, represented mainly as if–then rules rather than through conventional procedural code.
- The first expert systems were created in the 1970s and then proliferated in the 1980s.

Expert Systems

- Expert systems were among the first truly successful forms of artificial intelligence (AI) software.
- An expert system is divided into two subsystems: the inference engine and the knowledge base.
- The knowledge base represents facts and rules. The inference engine applies the rules to the known facts to deduce new facts.
- Inference engines can also include explanation and debugging abilities.

Expert Systems

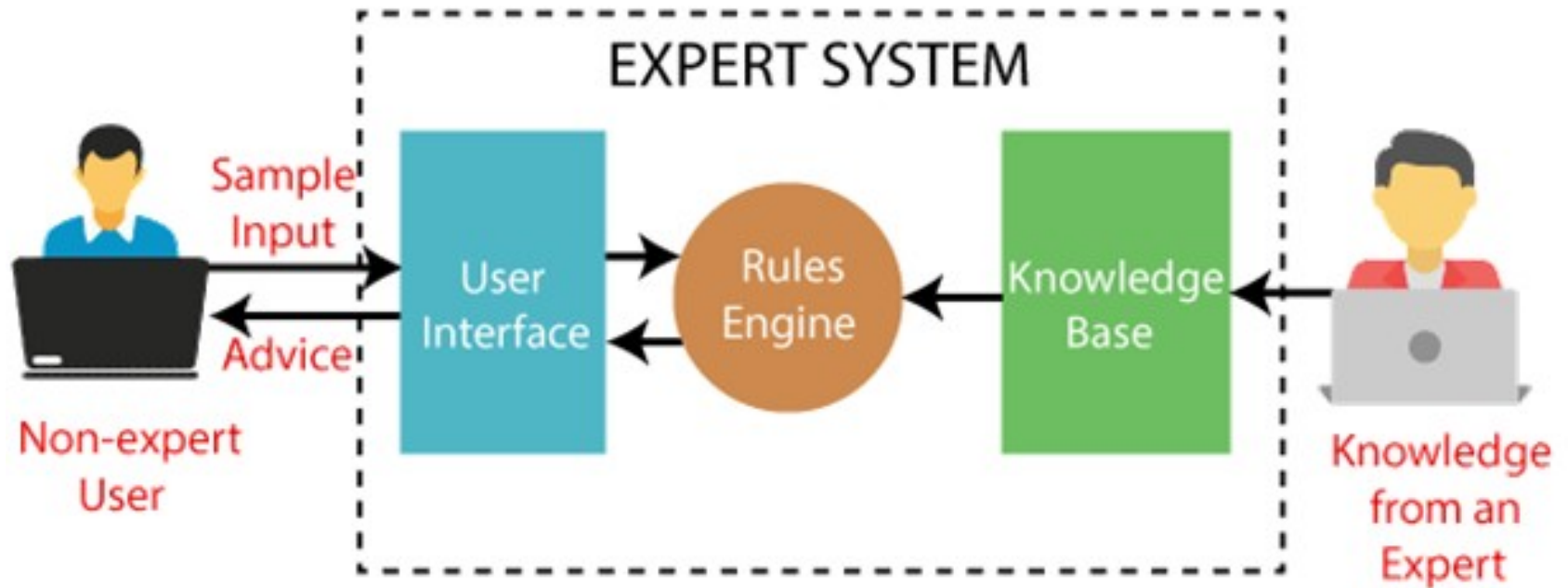

Deep Blue

- Deep Blue was a chess-playing supercomputer developed by IBM. It was the first computer to win both a chess game and a chess match against a reigning world champion under regular time controls.
- Development for Deep Blue began in 1985 with the ChipTest project at Carnegie Mellon University.
- IBM hired the development team when the project was briefly given the name Deep Thought. In 1989, it was renamed Deep Blue.
- Deep Blue first played world champion Garry Kasparov in a six-game match in 1996, losing 4–2. The computer was heavily upgraded and played once more against Kasparov in 1997.
- Having won the six-game rematch 3½–2½, it became the first computer system to defeat a reigning world champion in a match under standard chess tournament time controls. Kasparov accused IBM of cheating.

ROOMBA

- Roomba is a series of autonomous robotic vacuum cleaners sold by iRobot.
- Introduced in September 2002, they have a set of sensors that enable them to navigate the floor area of a home.
- These sensors can detect the presence of obstacles, particularly dirty spots on the floor, and steep drops (e.g. to avoid falling down stairs).
- As of 2021, iRobot markets models of their 600, i3, j7, and s9 series, while continuing to provide support and sell accessories for their previous series.

ROOMBA



IBM Watson

- Watson is a question-answering computer system capable of answering questions posed in natural language, developed in IBM's DeepQA project by a research team led by principal investigator David Ferrucci.
- Watson was named after IBM's founder and first CEO, industrialist Thomas J. Watson.
- The computer system was initially developed to answer questions on the quiz show Jeopardy! and, in 2011, the Watson computer system competed on Jeopardy! against champions Brad Rutter and Ken Jennings, winning the first place prize of \$1 million

IBM Watson



Google Now

- Google Now was a feature of Google Search of the Google app for Android and iOS.
- Google Now proactively delivered information to users to predict (based on search habits and other factors) information they may need in the form of informational cards.
- Google Now branding is no longer used, but the functionality continues in the Google app and its discover tab.
- Google first included Google Now in Android 4.1 ("Jelly Bean"), which launched on July 9, 2012, and the Galaxy Nexus smartphone was first to support it.

Amazon Echo

- Amazon Echo, often shortened to Echo, is an American brand of smart speakers developed by Amazon.
- Echo devices connect to the voice-controlled intelligent personal assistant service Alexa, which will respond when a user says "Alexa". Users may change this wake word to "Amazon", "Echo", or "Computer".
- The features of the device include voice interaction, music playback, making to-do lists, setting alarms, streaming podcasts, and playing audiobooks, in addition to providing weather, traffic and other real-time information.
- It can also control several smart devices, acting as a home automation hub.

Summary

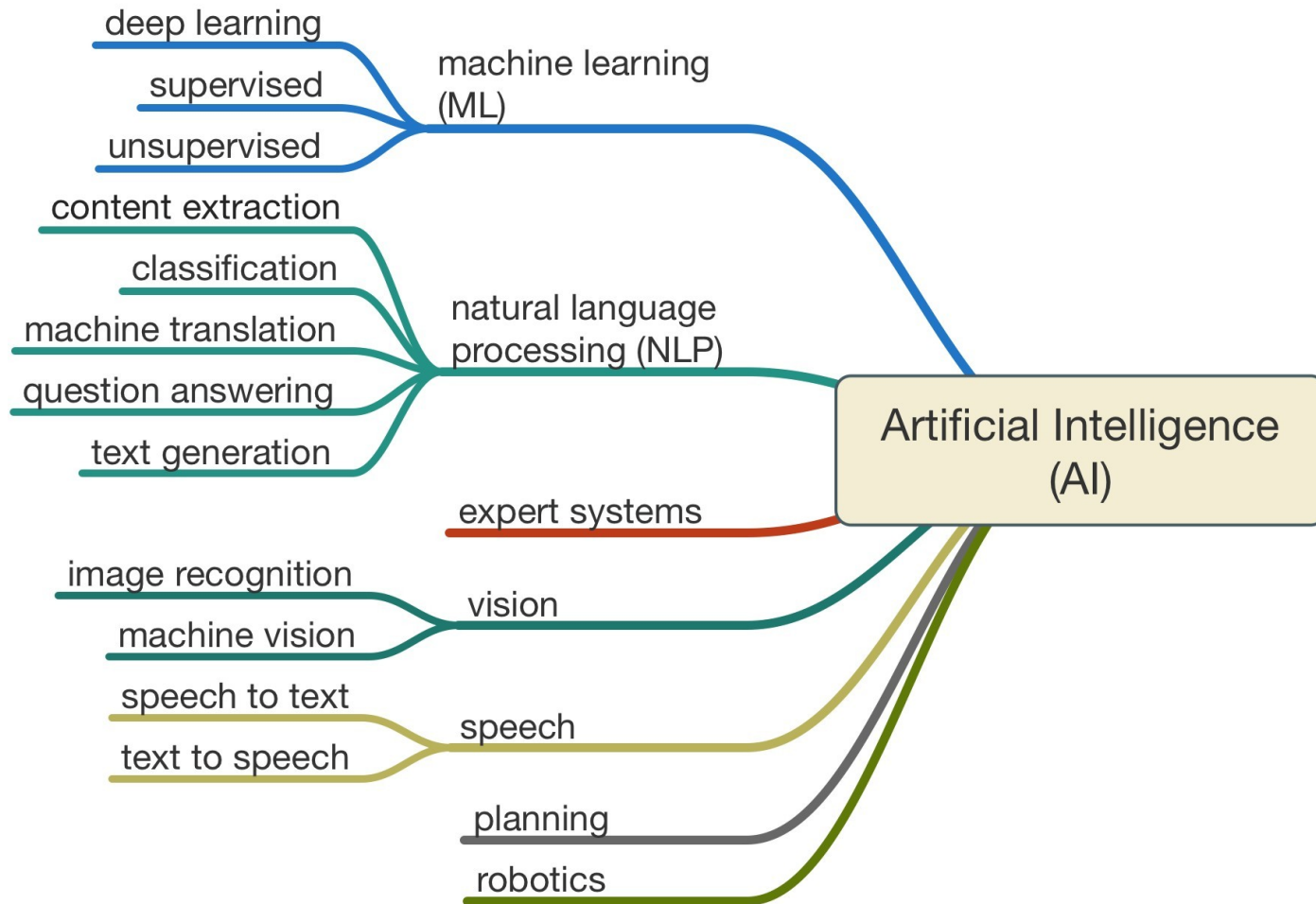

Thank you

This presentation is created using LibreOffice Impress 7.4.1.2, can be used freely as per GNU General Public License



@mitu_skillologies



@mITuSkillologies



@mitu_group



@mitu-skillologies



@MITUSkillologies

kaggle

@mituskillologies

Web Resources

<https://mitu.co.in>

<http://tusharkute.com>



@mituskillologies

contact@mitu.co.in

tushar@tusharkute.com